

SUNRISE™ Solar Signage Light

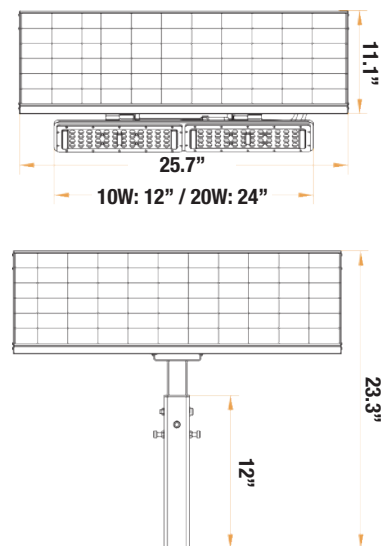

The Sunrise Solar UpLight is all in one design and comes complete with easy to install self-contained solar power assembly to run LED light fixture. Our Sunrise Solar Uplight is great for any monument sign, directional sign for any business and residential application. Our Uplight will bring security and sustainability with no electric bill and no maintenance. It features adjustable base mount from 15 inch to 24 inch for higher billboard/monument signs.

- Crystalline Solar panel with 45 degree tilted angle design
- Built in tempered glass solar panel, designed to provide self-cleaning operation between rainy and sunny days.
- Adjustable LED module design for lighting adjustment
- Integrated solar charge controller provided dusk to dawn operation
- First 4 hours at 100% brightness followed by 25% brightness until dawn
- Commercial grade adjustable base mount to ensure the fixture is at the right illumination height
- 2 Years limited warranty



SUNRISE™

Solar Signage Light

Specifications

Model #	SKU #	Power	PV Type	Solar Panel	Lumens	Rotation	Beam Angle	Working Time (Hrs)	IP Rating	Installation Height (Ft)
AVS-UPL-10W	786003	10W	MONO	10W	1000LM	180°	W80 X H50	26 HRS	IP65	12
AVS-UPL-20W	786004	20W	MONO	20W	2000LM	180°	W80 X H50	26 HRS	IP65	12



Made with high quality airplane-grade aluminum and has maximum 2000 lumens. It also has a LCD battery visual screen for clear visibility and the light division features 180° rotation to be adjusted to suit your needs. The Solar Uplight is the perfect solution to brightly illuminate your billboard signage.

Features

- Light automatically turns on and off
- Driven by solar energy
- Adjustable height (40-60cm)
- Max of 2000LM
- Air-plane grade aluminum
- Monocrystalline solar panel
- 180° module rotation for lighting adjustment
- Osram / Philips / Nichia LED Chips

Advantages

- Easy to install and operate
- Energy saving, long lifespan
- Height adjustable pole
- LCD battery visual screen

Applications

- Monument signs
- Directory signs
- Business signs
- Statues and memorials

Correlated Color Temperature

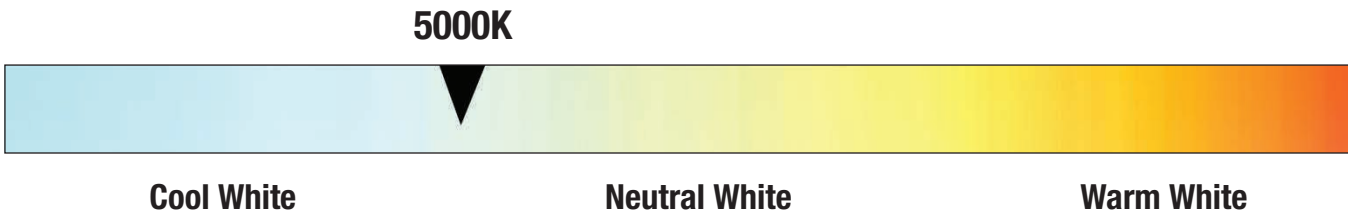

SUNRISE™

Solar Signage Light

Product Design and Benefits

Solar Uplight		
MODEL NUMBER	AVS-UPL-10W	AVS-UPL-20W
WATTAGE	10W	20W
SOLAR PANEL	10W (Mono)	20W (Mono)
LUMENS	1000LM	2000LM
BEAM ANGLE	W80° x H50° (Typical)	W80° x H50° (Typical)
DIMENSIONS (LIGHT PART)	300mm (12in)*195mm (8in)	600mm (24in)*195mm (8in)
WORKING TIME	26Hrs	26 Hrs
INSTALL HEIGHT	Minimum 30cm (12in)	Minimum 30cm (12in)
STORAGE TEMPERATURE	0°C~+45°C	0°C~+45°C
ROTATION DEGREE	180°	180°
IP RATING	IP65	IP65

FEATURES



LCD Display Screen



180° Rotation



SUNRISE™ Solar Signage Light

Product Design and Benefits

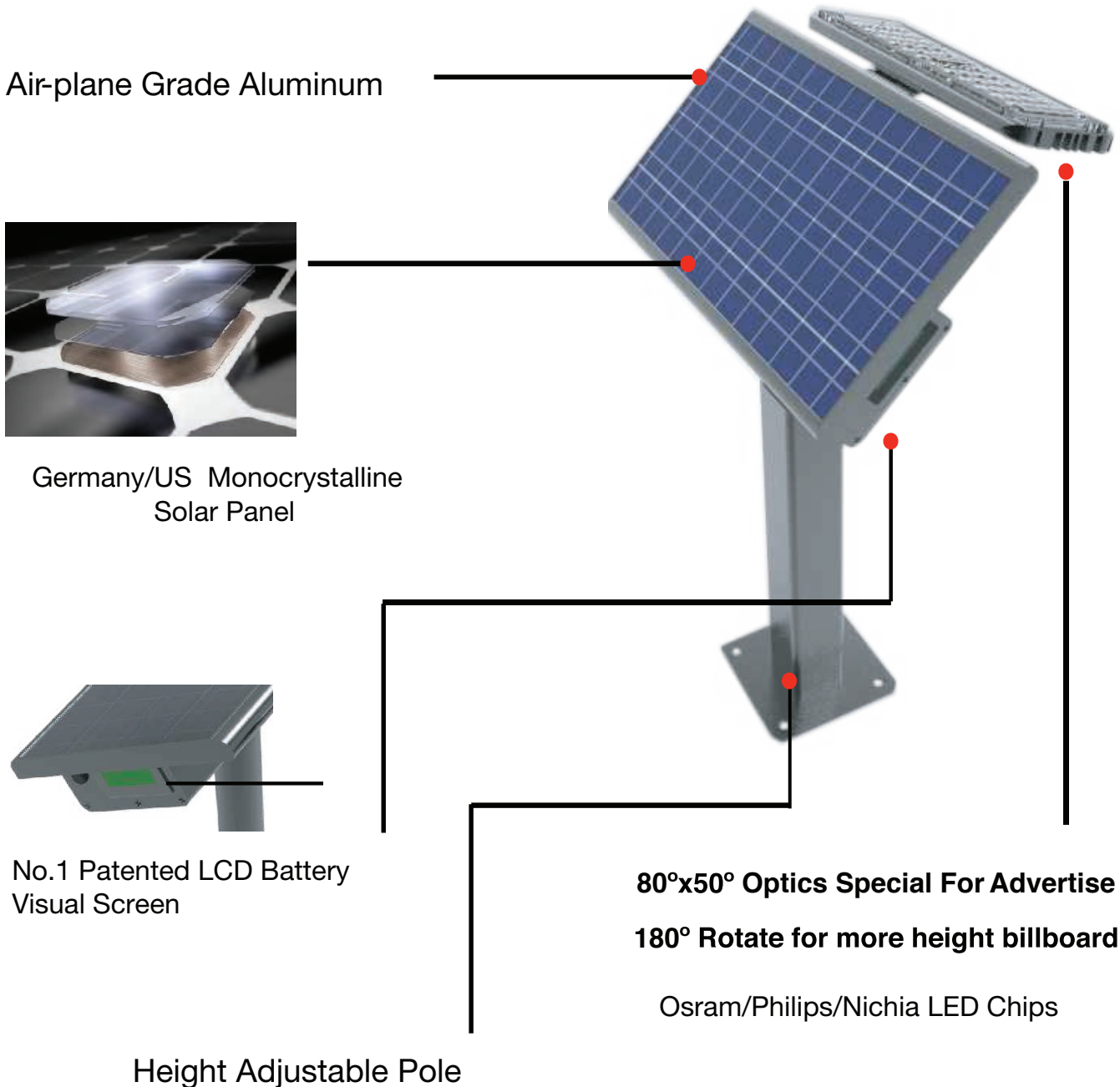

SOLAR SIGNAGE LIGHT



SUNRISE™

Solar Signage Light

Optimum Panel Orientation

The Solar charge in a battery pack won't last forever. The off-grid system relies on stored solar energy for autonomy. Angling your solar panels properly can boost the power intake of your solar lighting system. You want to angle your solar panels at a tilt based on the area's latitude.

Tip for Maximum Power

You can increase the tilt 15° in the winter or decrease 15° in the summer. In this way you can get the maximum sunlight to recharge the battery.

Best Facing Direction of Solar Panel

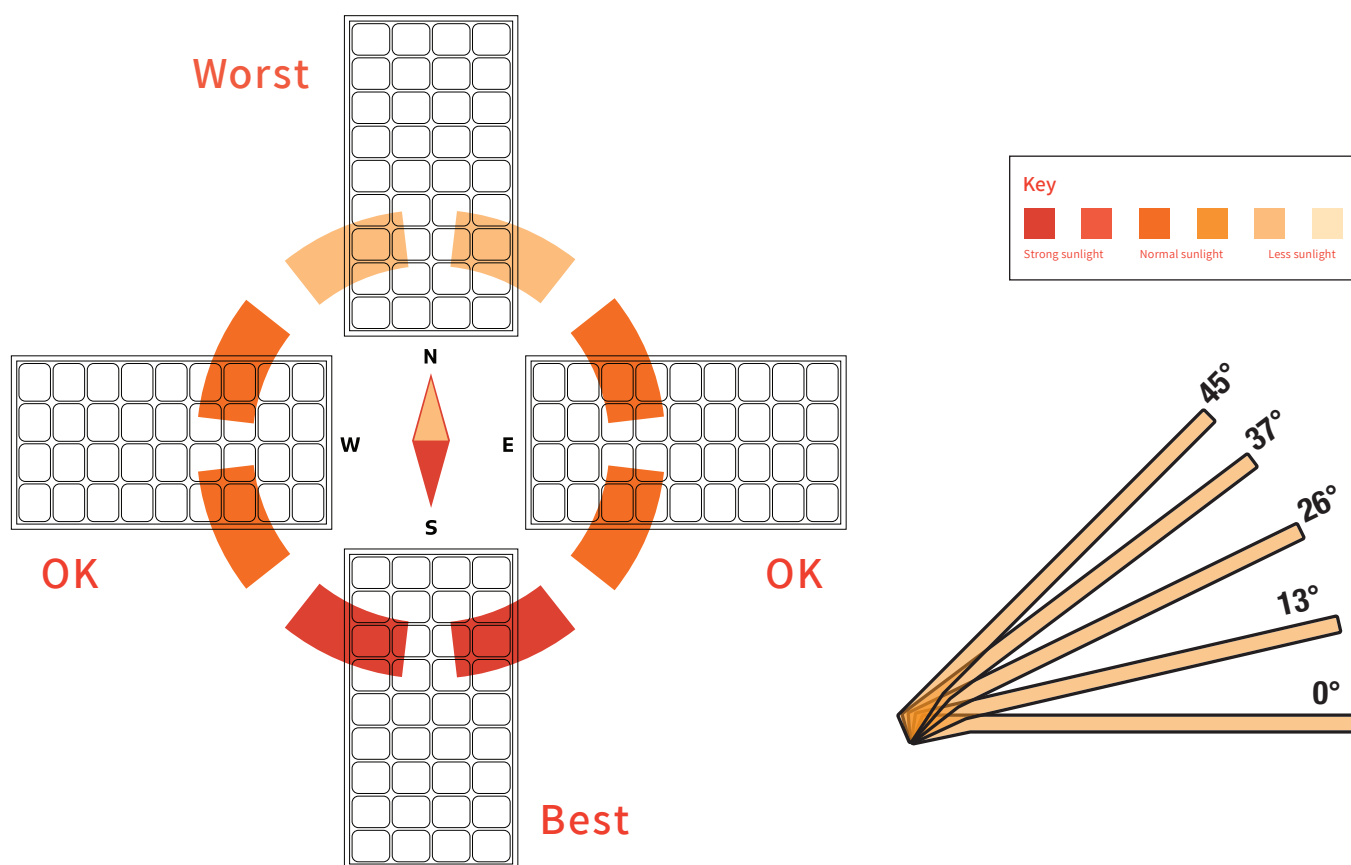

The area will dictate the installation of the fixtures and will sometimes prevent the lights from facing south. Panels facing West & East won't get as much light as Southern facing panels, but will still collect a good amount of sunlight. A North facing panel also works, but it will take longer to charge than any other direction. This would mean that the solar charge will be less optimal if installations are facing North.



SUNRISE™ Solar Signage Light

Optimum Panel Orientation

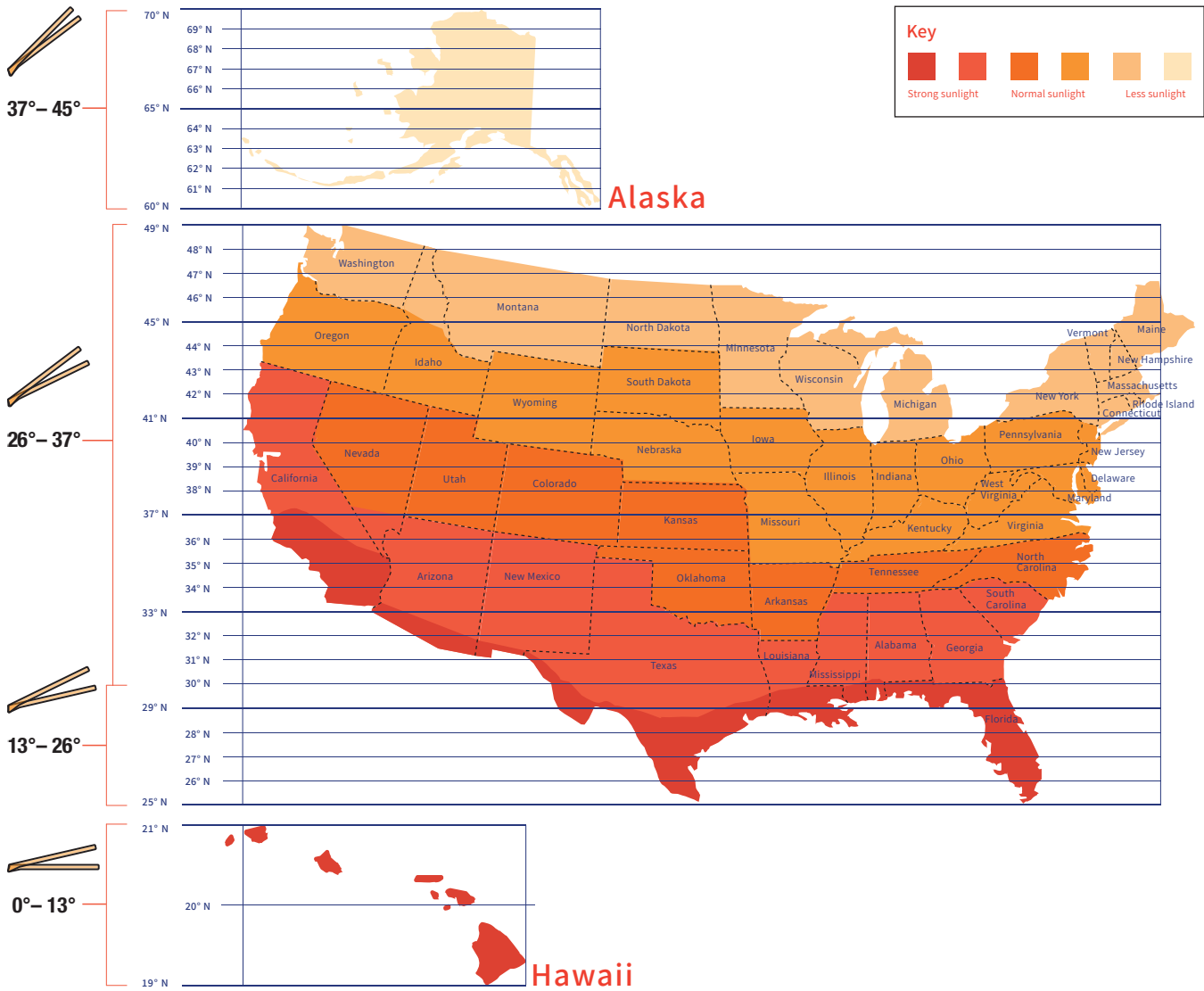

SOLAR SIGNAGE LIGHT

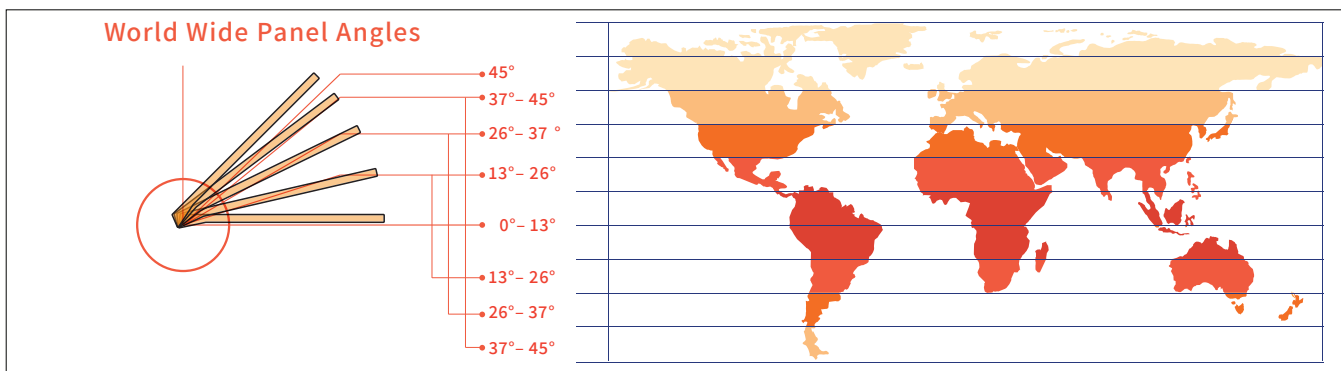

SUNRISE™ Solar Signage Light



SOLAR SIGNAGE LIGHT



SUNRISE™ Solar Signage Light



SOLAR SIGNAGE LIGHT

